

記號 MARK	設變內容 MODIFICATION	日期 DATE	修改 DRAW	核准 APPROVE
△				

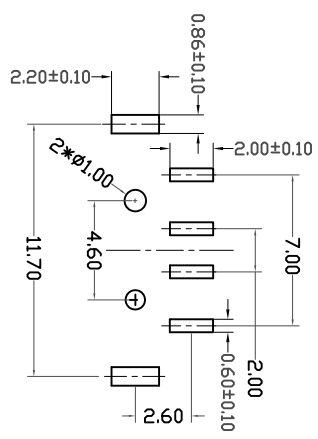
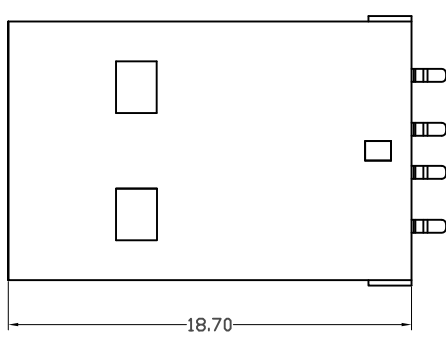
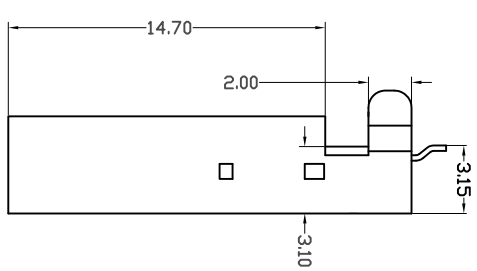
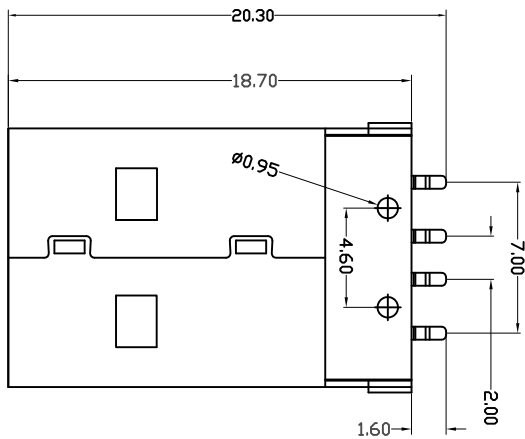
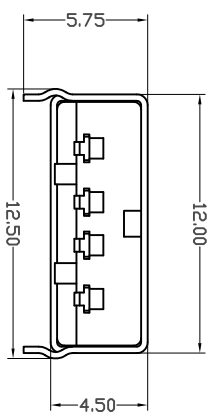

LAYOUT P.C.B

NOTE:

- MATERIAL
 - HOUSING: PA9T GLASS FIBRE UL94 V-0;
 - CONTACT: BRONZE T=0.25±0.02mm (SURFACE PLATING: Au1u"+Sn80~100u"+Ni60u")
 - SHEEL: SPCC-SD: T=0.30±0.02mm (SURFACE PLATING: Cu80~100u" Ni100~120u")
- ELECTRIC:
 - CONTACT RESISTANCE: 30 MILLIOHMS MAX
 - INSULATION RESISTANCE: 1000 MEGA OHMS MIN
 - DIELECTRIC VOLTAGE: 500V AC ONE SEC LEVEL
 - OPERATING TEMPERATURE: -55°C~ 85°C
 - OPERATING LIFE: 1500CYCKES

UNLESS OTHERWISE SPECIFIED TOLERANCES ARE		±0.30	單位	名稱 / 料號	USB A公鑰 5.7mm L版 9x8.6mm 18K
X°	±0.20	MM	Title / Part No.	USB-AM0482-1B	顏色
,XXX	±0.10	比例	Material		版本
X°	±2.0°	1:1	角法		00
,XXX°	±1.0°	頁次	PROL.		
App. By/Date	Draw / 日期	SHEET	REV.		
Check By/Date	審核 / 日期	1/1			
批准 / 日期	批準 / 日期				

丞永实业有限公司
BLUE SOURCES ELECTRONICS CO, LTD.